



Evolution of Dedicated Transmission System Networks for Oil & Gas Pipelines

CONTENT



Abstract	3
Abbreviations	4
Legacy Dedicated Networks	5
Next Generation Dedicated Networks	7
Comparative Analysis	9
The Path Forward... ..	11
Conclusions	12
About The Company	13
About The Author	13

ABSTRACT

With rapid evolution of technology in digital transmission systems, the dedicated transmission system networks for Oil & Gas pipelines have also been evolving and benefitted immensely. These evolutions in dedicated transmission networks (DNW) have fulfilled different types of functional requirements for Operations and Maintenance of pipelines.

The end user requirements have changed drastically from legacy voice and low speed serial data interfaces to bandwidth “hungry” applications, which are mostly Ethernet based. The boundaries between telecommunication systems and data networking devices are overlapping to some extent. The new requirements such as Intranet LAN, MIS LAN, Office LAN, VPN LAN, SAN LAN, SCADA LAN, VoIP LAN, SAP LAN and even CCTV LAN have been the main catalyst for these advances. These different types of LAN were extended/interconnected between different stations along the pipeline using data networking devices such as Routers and Layer 2 Switches. For this interconnectivity, legacy dedicated networks are providing typically PDH payloads such as 2 Mbit/s, 34 Mbit/s and 45 Mbit/s directly over the higher order PDH or SDH transport backbone. These types of solutions have some inherent disadvantages such as scalability, interface compatibility issues, complex management and increased maintenance. Further, this also required extensive involvement of experts from both telecommunication and IT department of the organization.

The advances in technology and compactness of transmission equipment has resulted in Next Generation SDH transmission equipment with Multiple Services Provisioning capability such as TDM, ATM and Ethernet, which is also called as MSPP equipment (Multiple Service Provisioning Platform). With the availability of MSPP, there has been paradigm shift in provisioning various services to end-user. By provisioning, the Ethernet based services directly from Next Generation SDH equipment, the dedicated transmission network designing and deployment is easier, quicker and hassle free. By using different configuration of Ethernet over SDH (EoS) such as Ethernet Private Line (EPL), Ethernet Virtual Private Line (EVPL), Ethernet Private LAN (EPLAN) and Ethernet Virtual Private LAN (EVPLAN), SDH transport network

have become bandwidth efficient and started offering Quality of Service in bandwidth provisioning as per customer SLA. Most of these MSPP also supports Wavelength services for bandwidth scalability.

This technical paper throws light on evolutions of DNW in terms of technologies, functional requirement, applications, network architectures and network management systems. In the following section, this paper describes the architecture, systems/sub-systems and end-user functional requirement fulfilled by Legacy Dedicated Networks. The subsequent section describes the drivers for the next generation dedicated networks and shaping of these networks, followed by the path forward and comparative analysis of both networks.

Although, this paper focuses on dedicated networks of oil & gas pipeline industry, there exists lot of similarity with dedicated networks used in utility sector such as Railways, Power, etc.

ABBREVIATIONS

ATM	Asynchronous Transfer Mode	PIR	Peak Information Rate
ASON	Automatic Switched Optical Network	PRI	Primary Rate Interface (2 Mbit/s)
ASTN	Automatic Switched Transmission Network	QoS	Quality of Service
CAPEX	Capital Expenditure	ROW	Right of Way
CCTV	Closed Circuit Television	RWS	Remote Work Station
CIR	Committed Information Rate	SAN	Storage Area Network
CP	Cathodic Protection	SAP	Systems, Application and Products in Data Processing
CWDM	Coarse Wavelength Division Multiplexing	SCADA	Supervisory Control And Data Acquisition
DCS	Distributed Control System	SDH	Synchronous Digital Hierarchy
DWDM	Dense Wavelength Division Multiplexing	SLA	Service Level Agreement
E&M	Earth and Mark (Ear & Mouth)	TDM	Time Division Multiplexing
EoS	Ethernet over SDH	VCAT	Virtual Concatenation
EPL	Ethernet Private Line	VLAN	Virtual Local Area Network
EPLAN	Ethernet Private Local Area Network	VoIP	Voice over Internet Protocol
EVPL	Ethernet Virtual Private Line	VPN	Virtual Private Network
EVPLAN	Ethernet Virtual Private Local Area Network	WAN	Wide Area Network
FXO/FXS	Foreign Exchange Office/Foreign Exchange Subscriber	WDM	Wavelength Division Multiplexing
GFP	Generic Framing Procedure	xDSL	Digital Subscriber Line (x = Asymmetric, Symmetric, etc)
GUI	Graphical User Interface		
LAN	Local Area Network		
LCAS	Link Capacity Adjustment Scheme		
MIS	Management Information System		
MSPP	Multi Service Provisioning Platform		
NMS	Network Management System		
NZDSF	Non Zero Dispersion Shifted Fiber		
O&M	Operations & Maintenance		
OPEX	Operational Expenditure		
PABX	Private Automatic Branch Exchange		
PDH	Plesiochronous Digital Hierarchy		
PHY	Physical		

LEGACY DEDICATED NETWORKS

The legacy dedicated networks are focused mainly on voice and low speed data connectivity (19.2k... 64k or nx64k) typically from Master station/ Control Center to Valve stations/Remote CP stations along the pipeline. This type of connectivity required the aggregate transport bandwidth of 2 Mbit/s (E1) or multiples of 2 Mbit/s such as 8 Mbit/s, 34 Mbit/s and in some cases up to 140 Mbit/s (prior to SDH technology). However, from cost effectiveness & future expansion point of view, most of the legacy dedicated networks started adopting SDH STM-1, STM-4 and STM-16 transport backbone, in order to fulfill the captive requirement as well as bandwidth leasing for revenue generation. In nutshell, the legacy dedicated networks are fully based on TDM technology with TDM payloads.

The voice connectivity is provided in the form of omnibus (conference) phones or subscriber extended from central PABX using FXO/FXS interfaces. As the O&M activities are mostly coordinated from control center, this type of voice connectivity was more than sufficient. However, with change in pipeline operation philosophy wherein the regional controls are required, it is imperative to have more than one PABX and interconnect them over E&M or PRI trunks. This resulted in requirement of higher order PDH & SDH systems.

The data connectivity is mainly point-to-point or point to multipoint low speed data communication for SCADA/DCS systems. The data rate for this connectivity is typically 9.6 kbit/s to 19.2 kbit/s. For some other applications such as SCADA RWS connectivity to SCADA Master, Router & EPABX interconnectivity, the data rate up to 64 kbit/s and n x 64 kbit/s are used.

The above-mentioned voice and data connectivity are provided using Primary Multiplexer with suitable data and voice channel interface units. Different variants of Primary Multiplexers are deployed such as Terminal, Drop/Insert and even in the form of cross connect at

Strategic location e.g. spur-originating locations.

These Primary Multiplexers are mostly in Chain configuration, which comprise of Terminal Multiplexer at terminal ends and Drop/Insert Multiplexers at intermediate locations such as Valve stations/RCP stations along the pipeline.

Majority of the legacy dedicated networks are deployed with two tier architecture which typically comprise of high order PDH or SDH transport layer

(backbone); acting as one of the protecting path and access layer of Primary Multiplexers with voice and data channel units, as shown in

Figure-1. Some of these networks have two transport layers of SDH. {It may please be noted that definitions & scope of transport and access layer depends on the context in

which they are referred to. For example, wavelength based backbones such as WDM, CWDM or DWDM, refers to SDH or equivalent payloads as access layer}.

This type of architectures provided lots of benefits such as expansion, alternate routes, formation of ring topology, etc.

In order to provide high network resilience in these networks, path protection (1+1) and different topologies are deployed which include ring, star and hub topologies. These topologies and path protection (1+1) are aimed at providing protection of traffic on point-to-point traffic against path failure and equipment failure. However in typical configurations such as Chain configuration of Primary Multiplexer, the protection against equipment (Primary Multiplexer) failure is not available. This limitation is overcome by deploying Loop Protection feature of Primary Multiplexer that provides protection of individual channel (64k) against equipment failure (& path failure as well) by automatically re-routing channel in ring, as shown in Figure-2. (Page 6)

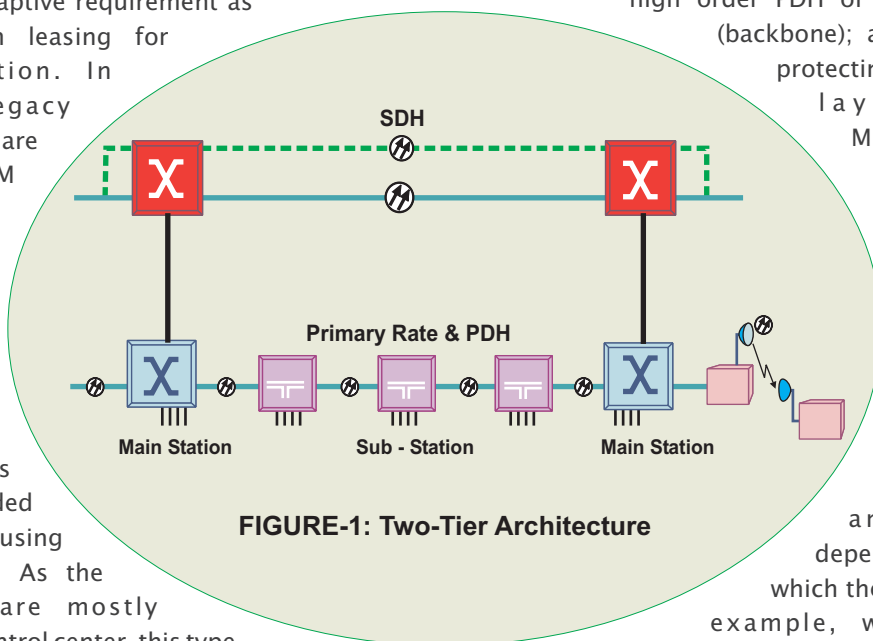

FIGURE-1: Two-Tier Architecture

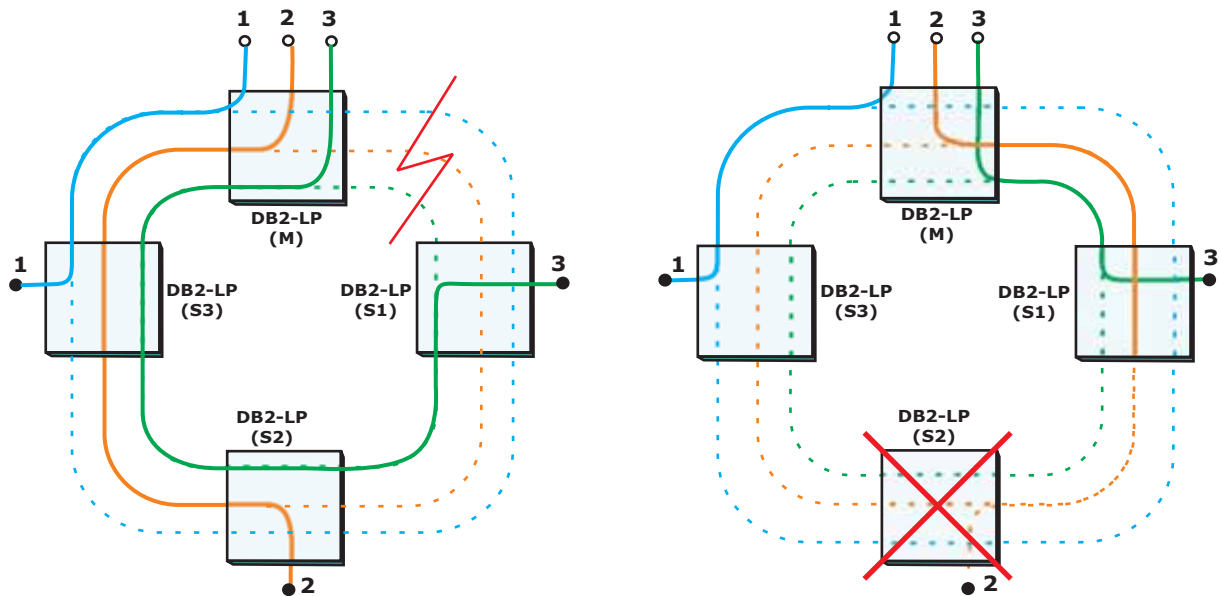

FIGURE-2: Loop Protection Architecture

Such feature is available in Nokia DB2-LP (Loop Protected) drop insert multiplex equipment.

The transport backbone for these networks is mainly fiber optic based due to availability of right of way for installation along the pipeline. In order to overcome the limitation on up gradation of transport backbone due to high dispersion in ITU-T G.652 compliant fibers, some networks are deployed with non-zero dispersion shifted (NZDSF) fibers compliant to ITU-T G.655 specification that has little dispersion. These types of fibers are also suitable DWDM transmission systems with closely spaced wavelengths.

In some cases microwave communication is also used due to ROW issues and other circumstances in which optical fiber media cannot be used. Most of these microwave based network are now being planned for up gradation due to bottleneck in bandwidth enhancement.

As the Operations and Maintenance of pipelines is carried out from control center, the Network Management Systems (NMS) for monitoring and management of transmission systems elements are also installed at Control Center. The NMS facilitates different management functionalities i.e. FCAPS functionality, such as Fault Management, Configuration Management, Administration, Performance Management and Security Management. With the help of these functionalities, O&M activities are performed quickly and effectively.

Due to multi-vendor equipment (SDH and PDH) in the network, there exists corresponding NMS for management of respective equipment. This type of NMS architecture posed some operational difficulty

However, with advent of open interfaces such as SNMP, the Integrated NMS are available. These Integrated NMS offers single windows/screen approach to management of multi-vendor equipment in the network.

The Legacy dedicated networks are based on proven & tested TDM technology over the years. However, these networks does not support, Ethernet based services directly, which has posed limitations in providing new end user requirements in the networks. Most of these requirements are also bandwidth hungry, which require up gradation of transport backbone. There are many such different drivers are responsible for evolution of dedicated transmission network into Next Generation Dedicated Network as described in following section of this paper.

NEXT GENERATION DEDICATED NETWORKS

The Next Generation Dedicated Networks are based on Next Generation SDH equipment with Multi Service Provisioning Platform (MSPP), which not only provides TDM services, but also Ethernet services & Wavelength services. Various market drivers responsible for this evolution are:

■ **Service and transport convergence**

It was the requirement of networks that multiple service connections such as TDM and Ethernet services converge on to a single platform with SDH transport backbone.

■ **“Anywhere to anywhere” requires transport on SDH**

The SDH has been the dominant technology on fibre over a decade as proven and tested transport backbone. Various alternative technology decisions based on low capital expenditure (CAPEX) is misleading as they are vendor specific and non compliant to international standards.

■ **Standards for Ethernet over SDH available**

For Ethernet over SDH technology in NG SDH is adopted by most of equipment vendors due to rapid progress in VCAT, GFP and LCAS standards. These standards allow Interworking between different vendors, in similar manner to Interworking of TDM payloads over SDH.

■ **Solutions must address lower costs**

For any solution the CAPEX must be lower by offering the platform which is more flexible, multiservice supporting, scalable, lower power consumption, smaller footprint, support cards with high density and commonality. Further, OPEX should also be lower by using common processes & training and low maintenance.

With the availability of Next Generation SDH equipment, various Ethernet based services were possible directly through Layer 1 and Layer 2 Ethernet interfaces (of SDH) that were earlier realized through external hubs and switches, with limited WAN bandwidth. Due to standards like GFP, VCAT and LCAS, not only WAN bandwidth of Ethernet data streams increased multifold but also provided protection of traffic, by routing through different paths. For example, using LCAS (Link Capacity Adjustment Scheme), the Ethernet data mapped into multiple VC-x (x=12,3,4) containers is split and sent

across different paths. At the receiving end, these containers are again re-arranged and complete Ethernet data is made available. In case of failure of any path, the Ethernet data is available, albeit with reduced WAN bandwidth. This scheme (LCAS) facilitated efficient usage of bandwidth on optical path which otherwise would have to be reserved in the form of path protection scheme such as SNCP.

The Ethernet interfaces of SDH (EoS) allowed different type of Ethernet data transmission across the network using SDH

transport backbone. Most of the initial requirement was point-to-point LAN extension called as Ethernet Private Line (EPL) in which dedicated TDM bandwidth is allocated as shown in following **Figure-3:**

In contrast the EPL, Ethernet Virtual Private Line (EVPL) shared the WAN bandwidth, thereby increasing the efficiency, as shown in **Figure-4.**

It can be seen that EVPL services allowed aggregation of Ethernet streams into a single Ethernet PHY port called as Access Aggregation, thereby reducing number of Ethernet ports required to extend Ethernet from head end location to multiple locations in network.

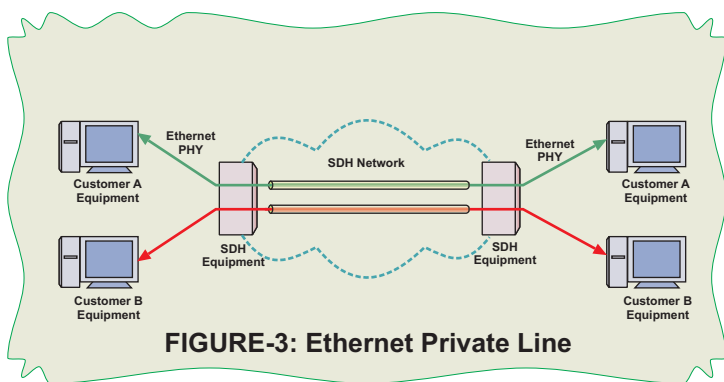

FIGURE-3: Ethernet Private Line

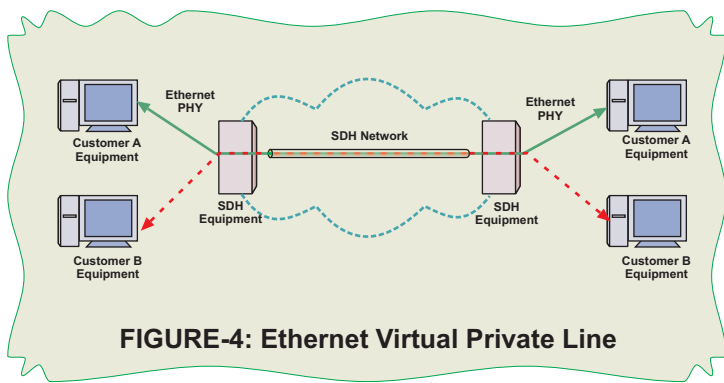

FIGURE-4: Ethernet Virtual Private Line

Other type of EoS configurations are either point to multipoint or multipoint to multipoint, which are called as Ethernet Private LAN (EPLAN) and Ethernet Virtual Private LAN (EVPLAN). In case of EPLAN, LAN connectivity among different locations is provided through dedicated TDM bandwidth and various transport topologies, which support this, are as shown in Figure-5 & Figure-6 below:

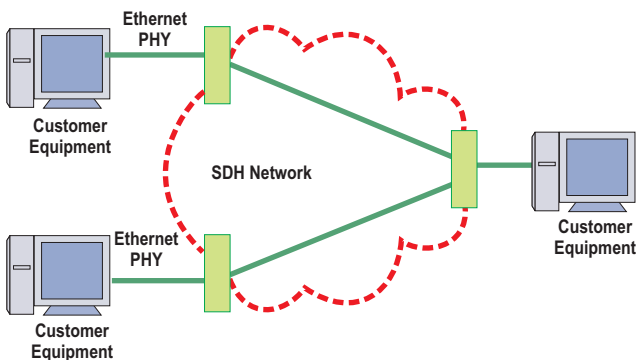

FIGURE-5: Edge Node serves as Bridge or router

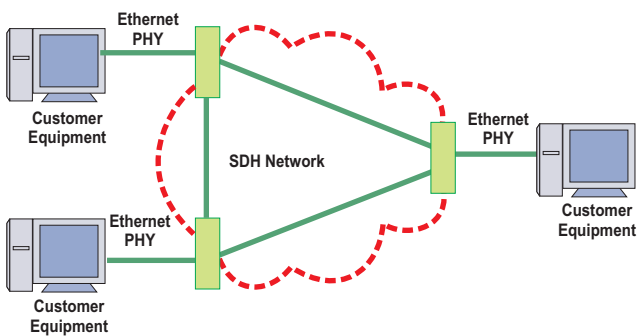

FIGURE-6: Mesh Type Connectivity

EVPLAN is a combination of EVPL and EPLAN. The transport channel bandwidth is shared among different customers, as are the routers in the SDH network. Ultimately, the sharing of bandwidth in the transmission channels and switch fabrics gives EVPLAN the potential for very cost-effective carrier network resource utilization. Clearly, however, EVPLAN is the most complicated network architecture to manage.

The EPL services operate at Layer 1, wherein all characteristics of Ethernet frame are preserved which is why it is also called as Transparent LAN service. The EVPL, EPLAN and EVPLAN operate Layer 2 and Ethernet frames can be VLAN tagged at ingress and egress of Ethernet access and trunk ports. By using, QoS parameters such as CIR and PIR, different customer SLAs can be implemented.

As can be seen from different of LAN services available through Next Generation SDH equipment, opened up end less possibilities of transporting different Ethernet based application such as VoIP, CCTV, SCADA and many more. Most of the new pipeline networks demand these applications from operations and maintenance point of view.

For example, most of modern SCADA networks comprise of Master server, Standby server, Remote Work Stations and RTUs, geographically spread across the network to provide high availability of complete system. The EPLAN and EVPLAN offers best possible configuration of extending SCADA LAN across all the stations of network, irrespective of type of transport topologies.

Similarly the CCTV system which are based on distributed architecture comprising of NVMS, Client machine, Media Archive Servers and IP cameras; require extension of CCTV LAN to all stations of pipeline and in such case, using EVPL and EVPLAN configuration, the CCTV LAN can be extended with most efficient of use of bandwidth.

With the help appropriate QoS parameters for VoIP LAN using EVPLAN, the VOIP services can be implemented. This is very useful for VoIP network, which is very sensitive to loss, delay and jitter (delay variation).

All these end user applications directly serviced from Next Generation SDH equipment, the role of Network Management System became critical and required NMS with faster response, good Graphical User Interface (GUI) and User Friendly approach to ease the operation and maintenance of the network. Keeping in view this fact, the NMS system with geographical redundancy and integrated approach are implemented in most of the networks.

As most of the Next Generation Dedicated Networks, deployed Ethernet based applications; the use of circuit switched connectivity through Primary Multiplexers has been challenged. Although, most of interfaces and its characteristics available on circuit switched networks such as omnibus voice, omnibus data; cannot find its equivalent in packet switched networks. Moreover, the Ethernet based applications are faced with its own challenges, which are highlighted in next section.

COMPARATIVE ANALYSIS

As mentioned above in this technical paper, the Legacy Dedicated Networks and Next Generation Dedicated Networks have benefitted end users due to their characteristics but they also have some bottlenecks. Benefits and challenges in both the network types are as tabulated below:

Sr. No.	Legacy Dedicated Networks.	Next Generation Dedicated Networks
1	These networks are based TDM technology, which is proven over the decades and offer: Assured Quality of Service.	Although these networks are also based on TDM transport, most of them also deployed Wavelength based services (on transport). These networks are operational in recent times and yet to pass the test of time.
2	Most of end users have trained manpower on these networks and efficient, cost effective maintenance of these networks is achieved due to experience over the period.	The new services such as Ethernet based services requires training to existing manpower (telecom group), as most of the data networking functionality is now being served through these networks.
3	These networks supported circuit switched interfaces with fixed bandwidth from 64k to multiple of 2 Mbit/s. This limited the deployment of bandwidth hungry Ethernet based end user functional requirements.	These networks supported not only circuit switched interfaces but directly packet switched interfaces (applications).
4	These networks support the end user functional requirements with manageable delay and jitter characteristics, compliant to ITU-T standards.	Due to availability of Ethernet interfaces, these networks are suitable for Ethernet based applications, however the delay and jitter characteristics are governed by network layout, architecture and topology, which becomes challengeable incase of applications requiring low latency on end-to-end basis.
5	These networks provide excellent quality of voice and omnibus (conference) voice due to TDM technology. For mission critical activities, voice connectivity is very much important during operational & maintenance of pipelines.	<p>These networks supports VoIP networks in which Voice Quality is largely affected by different delays and other factors as detailed below:</p> <ul style="list-style-type: none"> <input checked="" type="checkbox"/> Codec delay conversion from analogue to digital and back to analogue <input checked="" type="checkbox"/> Processing delay packetization, addressing, routing, reassembly <input checked="" type="checkbox"/> Network delay traffic on network, congestion, prioritization <input checked="" type="checkbox"/> Jitter buffer delay waiting until full 1 second of the call is stored until it is heard

Sr. No.	Legacy Dedicated Networks.	Next Generation Dedicated Networks
		<ul style="list-style-type: none"> <li data-bbox="869 421 1460 495">☑ Packet Loss - need to resend packet (results in more delay or poor quality) <li data-bbox="869 533 1342 566">Echo - speaker hear him/her self talking <ul style="list-style-type: none"> <li data-bbox="917 607 1225 640">- Echo cancellers needed <li data-bbox="917 645 1460 712">- Quality of device on sending or receiving side should be good.

THE PATH FORWARD...

Going by the saying that “the only CONSTANT is CHANGE”, the Next Generation Dedicated Networks also continues to get new technology platforms to support new requirements and bring as much intelligence & automation possible in the network.

As the networks are becoming complex with multiple topologies co-existing, the planning and deployment of traffic protection mechanism becomes intricate. Moreover, the network (dedicated) growth is governed by business plan in tandem with market requirements; this makes more challenging for planning the network from day one. Also there are sometimes different service requirements and SLAs to be complied by networks.

The solution to all these problems is Automatic Switched Optical Network (ASON) or Automatic Switched Transport Network (ASTN), which comprise of Next Generation SDH equipment with CONTROL Plane (IP Intelligence plane) as shown in Figure-7.

The ASON/ASTN equipment is combination of switch, transmission & data with signaling & routing (Layer 3) capability through CONTROL Plane. The ASON/ASTN equipments support features like automatic traffic restoration in multipoint failure case, automatic Neighbour discovery, topology discovery, etc. Further ASTN/ASON are supported by ITU-T standards like G.8080, G.7714, etc. and also interoperability between the different manufacturer equipments is being conducted.

The use of ASON/ASTN equipment in dedicated networks of pipeline will be justified provided that significant unplanned network growth potential is there and cost economics and operational aspects make sense to end-user.

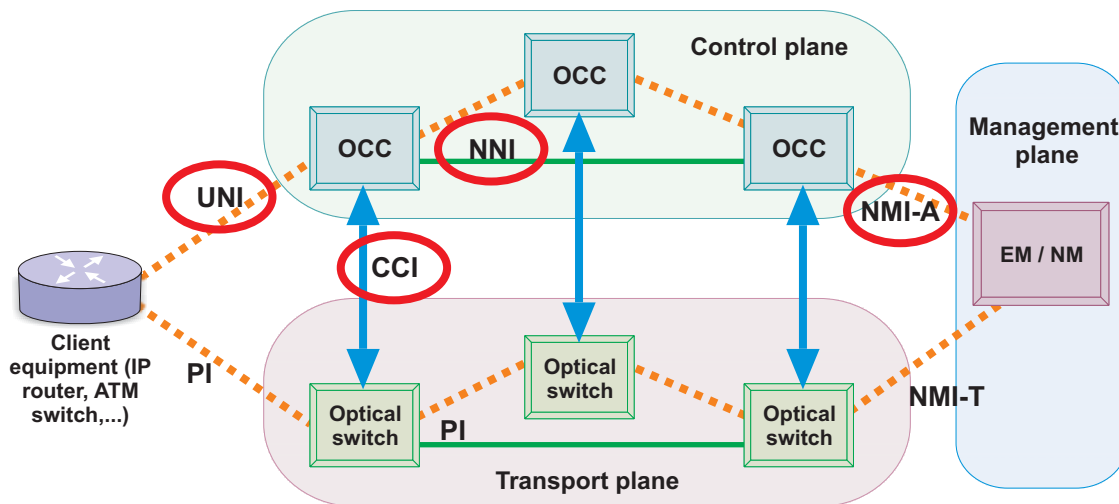

ASON is an Optical Transport Network (OTN) capable to switch automatically Optical Channels

- CCI : Connection Control Interface
- NMI - A : Network Management Interface for the ASON Control Plane
- NMI - T : Network Management Interface for the Transport Network
- NNI : Network to Network Interface
- OCC : Optical Connection Controller
- PI : Physical Interface
- UNI : User to Network Interface

FIGURE-7: ASON/ASTN CONCEPT

CONCLUSIONS

The convergence of technology has provided endless opportunities for end user applications. The benefits and challenges of this convergence are highlighted in this paper. Both Legacy and Next Generation dedicated transmission networks have their own characteristics, which benefited the end users. The Next Generation dedicated networks are based on advanced technologies with multi service provisioning capability while the Legacy dedicated networks are based on TDM technology which is well proven, matured and competence is in place to operate and manage these networks.

The paradigm shift has come in transport (SDH) technology to support bandwidth hungry Ethernet based applications. However, the circuit switched interfaces in the form of 64k/nx64k bandwidth for voice & data, through Primary Multiplexers will continue to co-exist with Next Generation SDH equipment with Ethernet support. Although, for voice connectivity VoIP

technology is available but so far it has been deployed in offices & campus wide networks and to some extent over public networks from cost economics perspective, albeit the quality of voice & echo in VoIP technology is always an issue. Further suitability of VoIP, for mission critical voice applications of pipeline operations is yet to be established. Both Primary Multiplexers and Next Generation SDH equipment are based on TDM technology. Thus, it is amply clear that **“TDM will never go away”**.

The Next Generation dedicated networks are in the phase of justifying their deployment from cost economics and maintenance perspective. As the complexity of networks increases and end user bandwidth demand grows, the technological platforms like ASON/ASTN will find its place in the dedicated networks of the future.

ABOUT THE COMPANY

Commтел is an engineering and technology-based company, which provides its customers with advanced telecommunications network products and services, which are highly reliable, value for money and supported for many years beyond commissioning. These networks are engineered for local and international customers to meet a variety of environmental operating conditions and to meet local and international standards.

The three principals Commтел prides itself on are engineering excellence, value for money and the ability to provide innovative solutions to better meet customer needs, and therefore Commтел promotes, fosters and maintains a culture where innovation is regarded as important as project and engineering excellence.

Being a dominant player in the dedicated network space for utilities in India, Commтел has vast experience in various transmission technologies such as PDH, SDH, DWDM, CWDM and xDSL. Commтел has partnered with Nokia Networks, Finland (as VAR), Marconi (Ericsson), Tejas Networks, WRI (China), Nortel Networks and ECI Telecom for their PDH, SDH & DWDM systems.

ABOUT THE AUTHOR

Nilesh Joshi is presently working with Commтел Networks Pvt. Ltd. as Head Technical Support, R&D since year 2000. He has experience of over 14 years in the field of digital transmission systems and fiber optics.

With hands on experience and in depth of knowledge in conceptualizing and designing of transmission networks based on narrowband and transport platforms, he has designed dedicated networks for many oil & gas industries projects in India and Middle East, using the equipment from major manufacturer such as Nokia, Marconi, Tejas Networks, WRI, etc.

Commтел Networks Private Limited
23, White Castle, 34-35, Union Park,
Chembur, Mumbai - 400 071.
Tel : +91 22 2520 1210
Fax :+91 22 2520 1220
Email : info@commtelnetworks.com
URL: www.commtelnetworks.com